

UNIVERSITY OF ILLINOIS  
AT URBANA-CHAMPAIGN

# Physics 403. Modern Physics Laboratory

*Summer 2022*  
*Eugene V. Colla, Alexey Bezryadin*



illinois.edu

# Physics 403 Modern Physics Laboratory

## Summer 2022 Teaching Team



**Eugene**

### Instructors:

**Eugene V Colla**  
[kolla@illinois.edu](mailto:kolla@illinois.edu)



**Alexey**

**Alexey Bezryadin**  
[bezryadi@illinois.edu](mailto:bezryadi@illinois.edu)



**Todd**

### Laboratory Specialist:

**Todd Moore**  
[tcmooore@illinois.edu](mailto:tcmooore@illinois.edu)

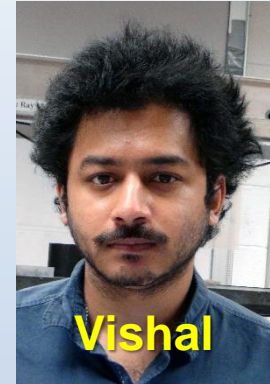

**Vishal**

### TA

**Vishal Ganesan**  
[vishalg2@illinois.edu](mailto:vishalg2@illinois.edu)



**Nathan**

**Nathan Arnold**  
[Narnold4@illinois.edu](mailto:Narnold4@illinois.edu)

**Support from Paul Kwiat Team**



**Sam**

**Samantha Isaac**  
[isaac5@illinois.edu](mailto:isaac5@illinois.edu)

# Outline

- I. **Goals of the course**
- II. **Teamwork / grades / expectations from you**
- III. **Syllabus and schedule**
- IV. **Your working mode**
  - In class and “**after hours**”—access
  - Safety, Responsibility
  - Home and away computing
- V. **Take a Lab tour**
- VI. **Let’s get started**
  - electronic logbooks** (*New advanced version designed by Rebecca Wiltfong*)



# Course Goals. Primary goals:

- **Learn how to “do” research**

- ✓ **Each lab experiment is a mini-research project**

- ✓ **How are experiments carried out ?**

**The procedures aren't all written out**

**The questions are not in the back of the chapter**

**The answers are not in the back of the book**

**You will have to learn to guide your own activities**

- ✓ **Use of modern tools and modern analysis and data-recording techniques**





# Course Goals. Primary goals:

- **Learn how to document your work**
  - **Online - electronic logbook \***
  - **Online – saving data and projects in student area on server**
  - **Using traditional paper logbooks**
  - **Making an analysis report**
  - **Writing formal reports\***
  - **Presenting your findings orally\***



# Course Goals. Secondary goals:

- **Learn some modern physics**
  - **Many experiments were once awarded by Nobel-prize**
  - **They touch on important themes in the development of modern physics**
  - **Some will provide additional insight to understand advanced courses you have taken**



# The Experiments. Three main groups

- **Nuclear / Particle (NP)**
- **Atomic / Molecular / Optics (AMO)**
- **Condensed Matter (CM)**

**You will do the experiment from all these groups**



# The Experiments

- Nuclear / Particle (NP)
  - Alpha particle range in gasses
  - $\gamma$ - $\gamma$  correlation experiment
  - $\gamma$  - spectroscopy

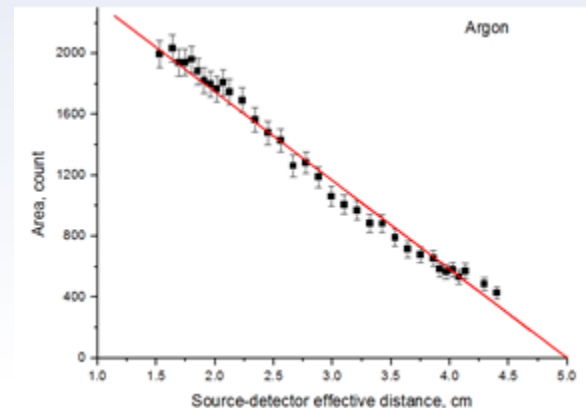
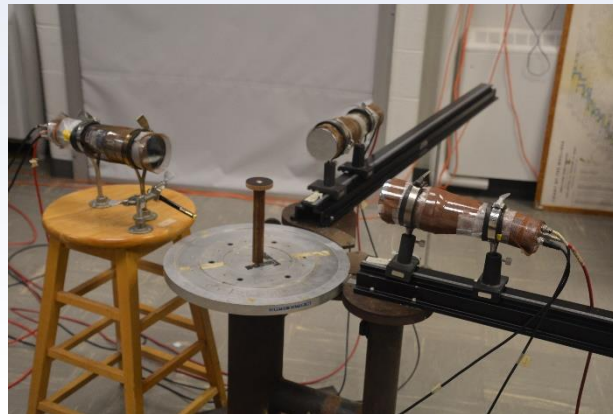
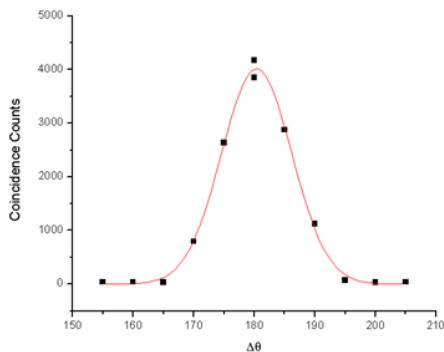
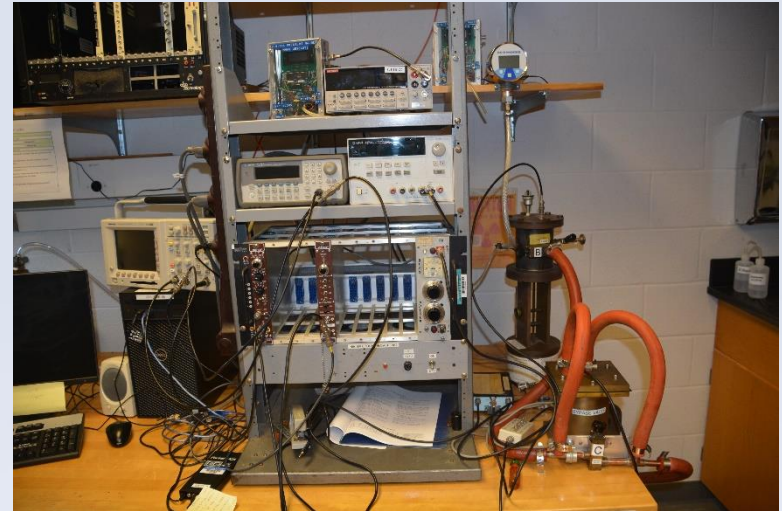



# The Experiments

## • Nuclear / Particle (NP)

### – Cosmic ray muons: \*

Lifetime, capture rate, magnetic moment

### – Angular distribution of cosmic rays

### – Mössbauer spectroscopy

\* Experiment is not offered in SU2022

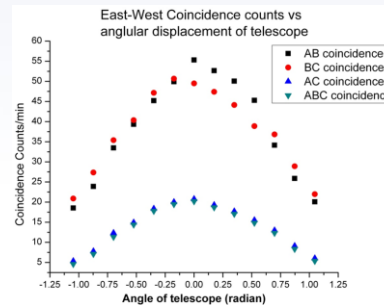
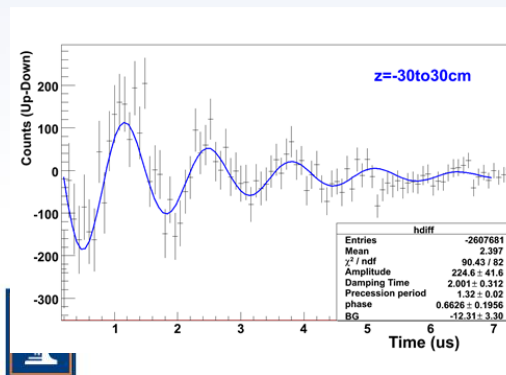
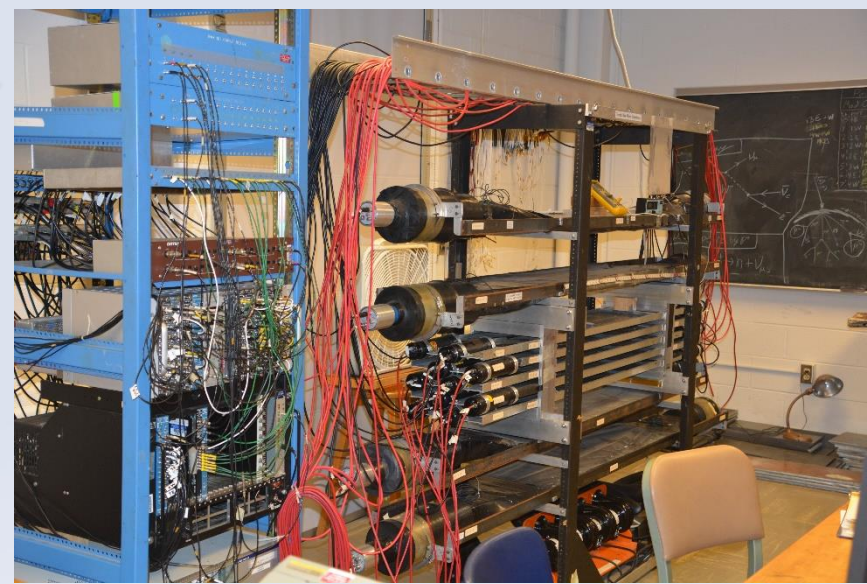

# The Experiments

## Atomic/Molecular/Optics (AMO)

- Berry's phase
- Quantum erasure
- Quantum Entanglement

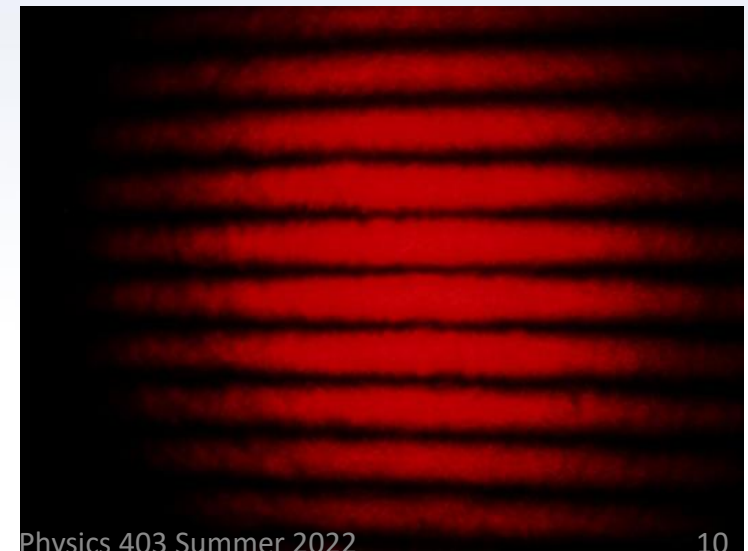
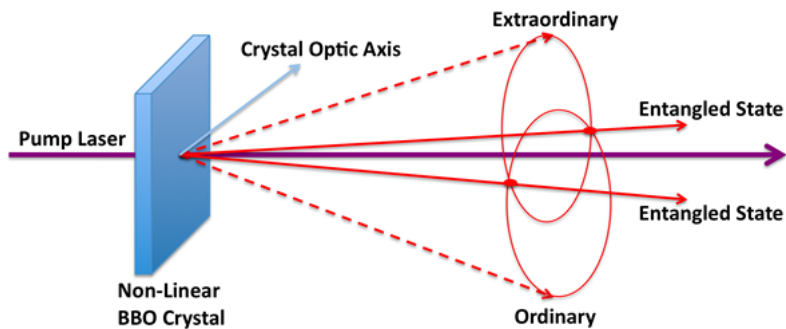
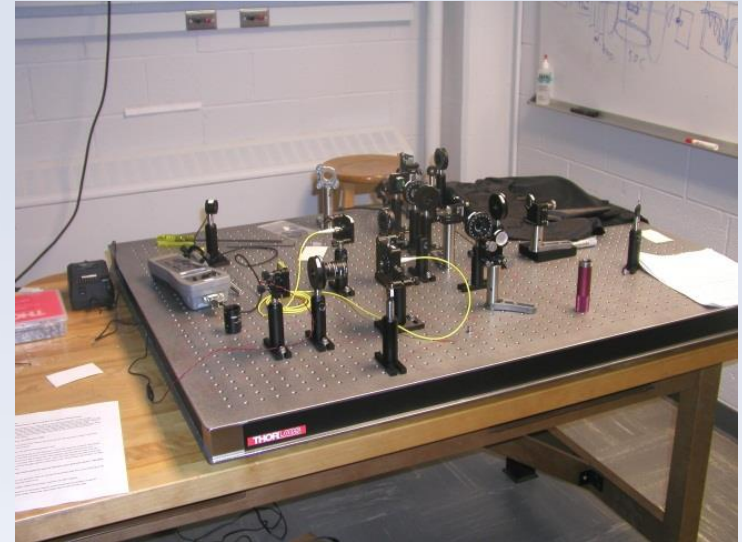



# The Experiments

## Atomic/Molecular/Optics (AMO)

- Optical pumping of rubidium gas
- Fluorescence spectroscopy

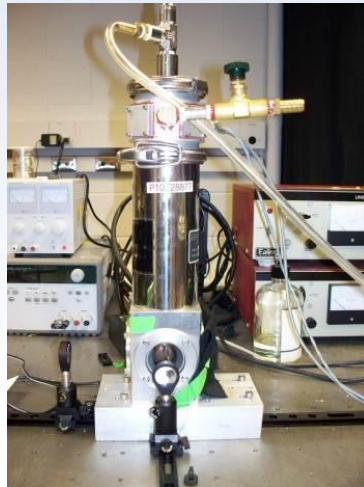
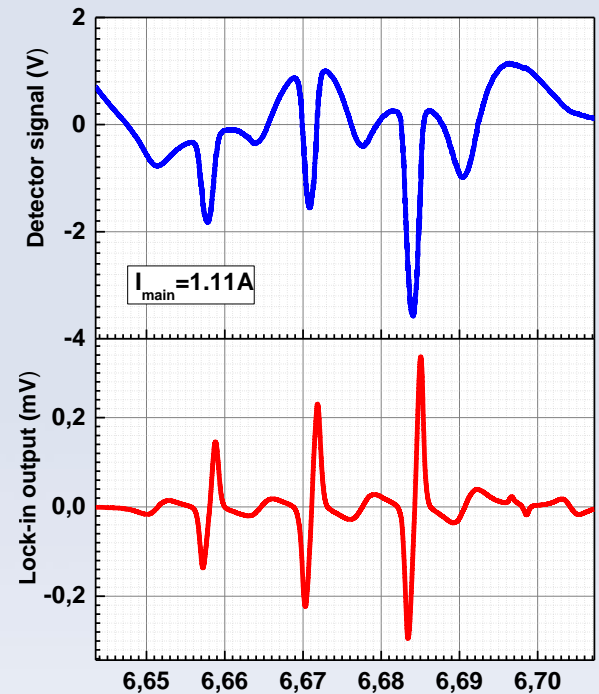

# The Experiments

- **Condensed Matter (CM)**
  - Superconductivity
  - Tunneling in superconductors
  - 2<sup>nd</sup> sound in <sup>4</sup>He superfluid state

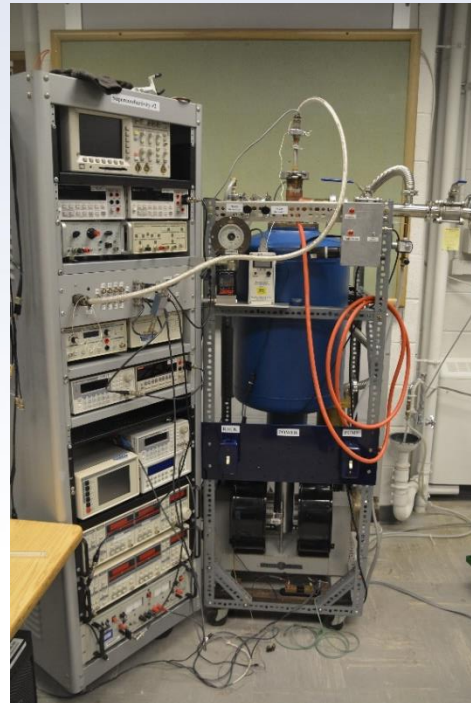

New: Superconductivity and magnetic field

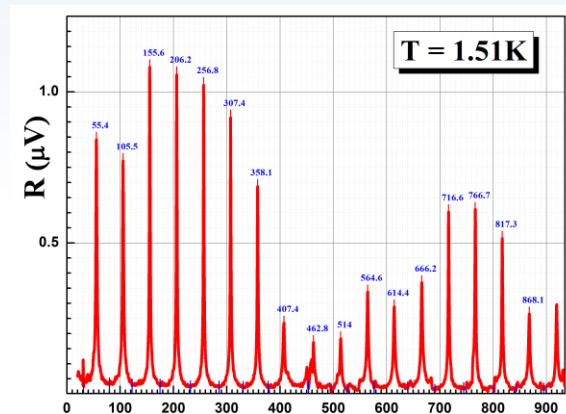
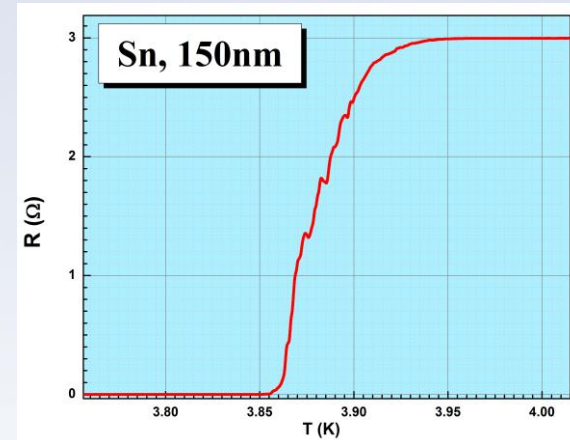
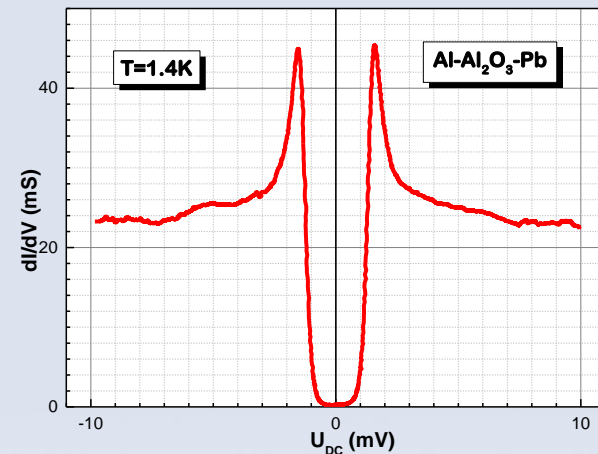



# The Experiments

- **Condensed Matter (CM)**
  - Ferroelectrics and ferroelectric phase transition
  - Pulsed NMR
  - Calibration of temperature sensors

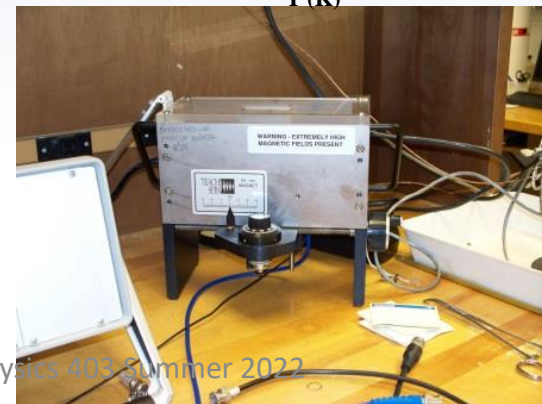
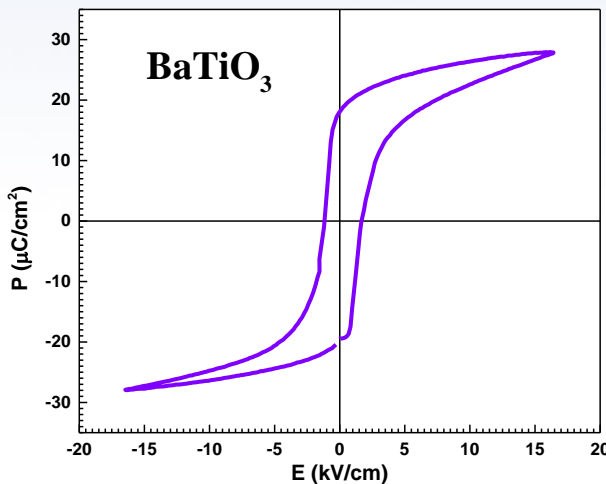
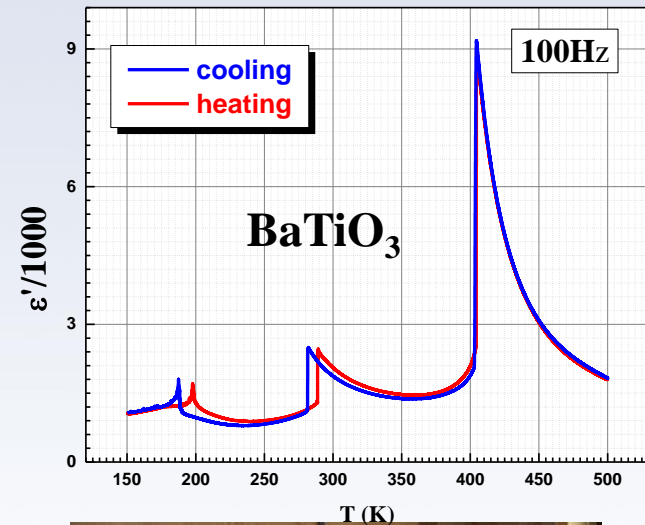
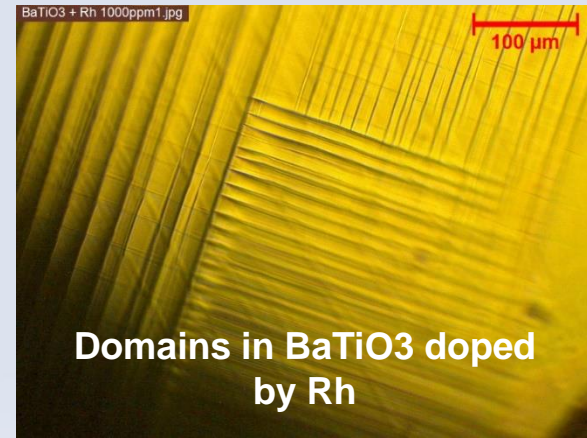

# The Experiments

- **Condensed Matter (CM)**
- **Special Tools:**
- **Vacuum film deposition**
- **Atomic Force Microscope**
- **Polarizing microscope**

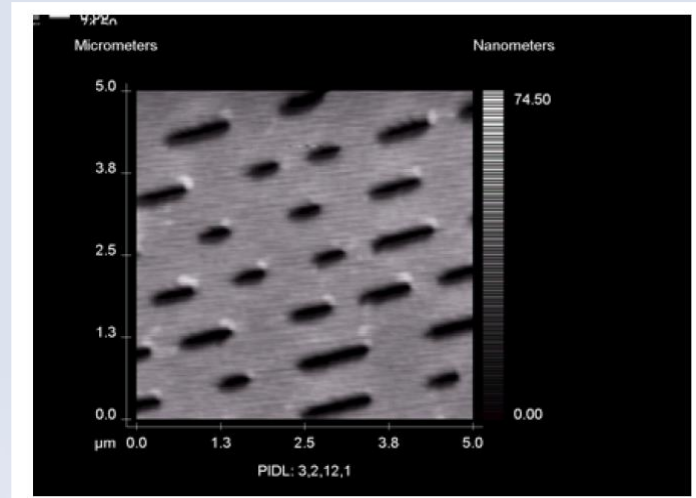

# The “manuals”

- Many are just guides
- An only few purchased experiments have “real” manuals
- We serve as your guides ... like real research ...
- We have prepared materials explaining how to do the experiments and data analysis, and you can find all these materials and examples of data analysis on the common drive.

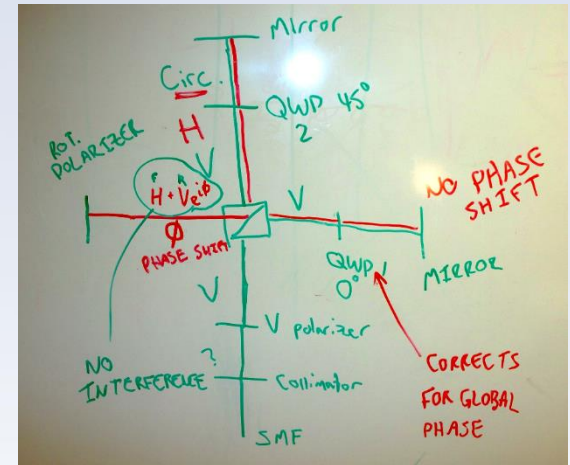
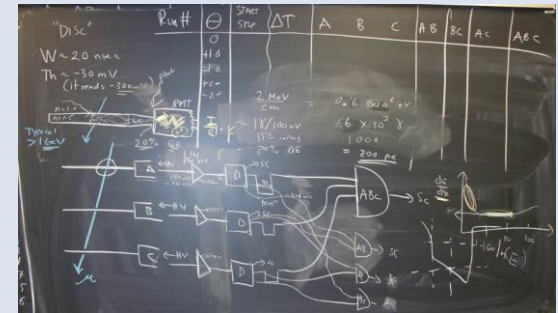

TEACH SPIN  
Instruments Designed for Teaching

**OPTICAL PUMPING  
OF RUBIDIUM  
OP1-A**



# Outline

- I. Goals of the course
- II. Teamwork / grades / expectations from you**
- III. Syllabus and schedule
- IV. Your working mode
  - In class and “after hours” access
  - Safety, Responsibility
  - Home and away computing
- V. Take a Lab tour !
- VI. Let’s get started
  - electronic logbooks
  - digital scopes





# Grading: Distribution of “740” points

<b>ASSIGNMENT</b>	<b>Points</b>
<b>Expt. documentation:</b> elog reports, shift summaries, plot quality; paper logbooks	<b>120 Total</b> <b>60 / cycle</b>
<b>Formal reports:</b> physics case, quality of results, depth of analysis, conclusions	<b>400 Total</b> <b>100 / report</b>
<b>1<sup>st</sup> Oral report:</b> motivation, organization of presentation; fielding questions	<b>100 Total</b>
<b>Final Oral Presentation <math>\equiv</math> Final Exam</b>	<b>120</b>
Total <b>Effective point total will be</b>	<b>740</b>

The grading scale will be a percentage out of “740” :

Letter grading scale is approximately **97% = A+**, **93% = A**, **90% = A-**, **87% = B+**, **83% = B**, **80% = B-**, etc

You can **RESUBMIT one lab report** to improve your grade  
(deadline for resubmissions and for report #4 **August 6<sup>th</sup> 2022**)



# Grading: a piece of history and analysis of the results

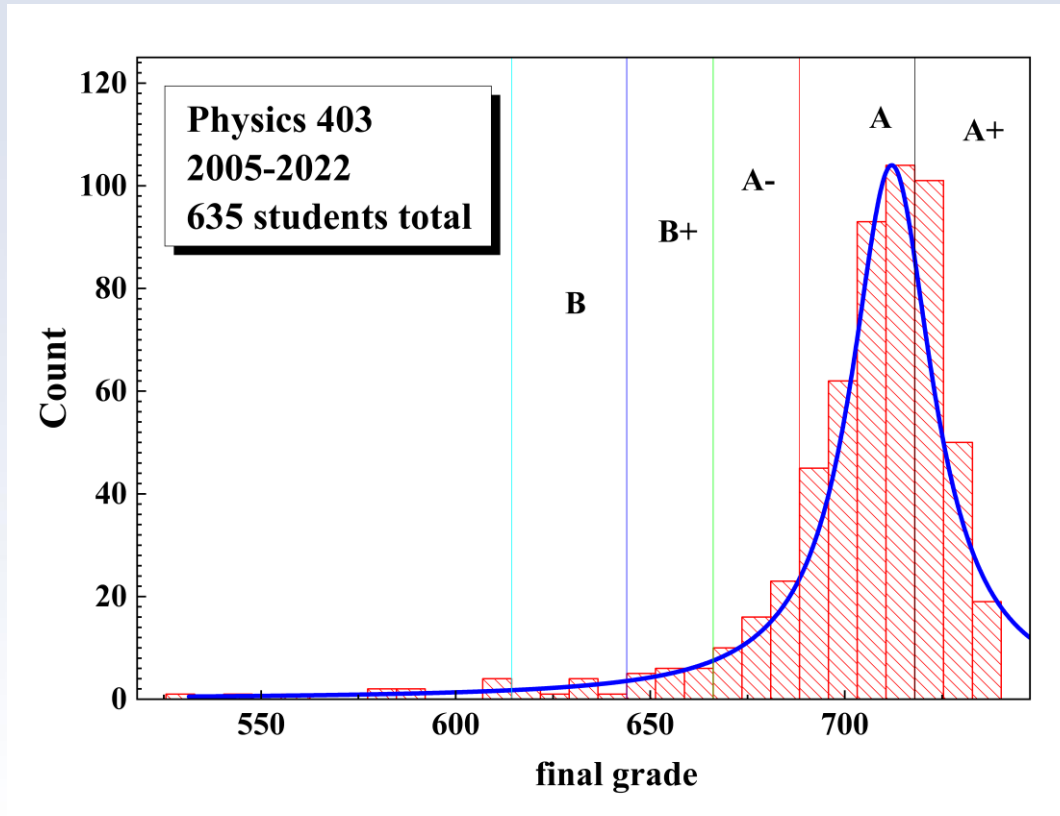

# Submission of Lab-Reports

- **Due dates as on syllabus at midnight**
- **The reports should be uploaded to the server:**
- **<https://my.physics.illinois.edu/courses/upload/>**
- **Accepted formats: PDF\* or MS-Word**
- **For orals – MS-PowerPoint\* or PDF**

*\* preferable*



# Absences

- If you are sick, **let Eugene know by email ([kolla@illinois.edu](mailto:kolla@illinois.edu))**. Don't come in and get others sick. We are working side-by-side in a close environment for many hours.
- ***COVID19 comment:*** if the student assigned to be “in person” can not attend the session he/she can be replaced by their partner and continue to work “online”.
- You can “make up” time by arranging with us and you can have access to the rooms. We will be accommodating.





# Absences. Excuse Policy.

- You can be excused from **only one** missed assignment, and only if you **provide medical or any other acceptable documentation**<sup>1</sup>.
- If the excused you have **missed the oral presentation** (oral #1), you have to discuss this with us, and we will arrange the date for your oral talk.
- The Final Oral **cannot be excused**, as it is equivalent to a final exam. **You cannot pass the course without credit for this assignment**<sup>2</sup>

1. Student Code: <https://studentcode.illinois.edu/article1/part5/1-501/>

2. Ibid: <https://studentcode.illinois.edu/article3/part2/3-201/>



# Late Reports

- **Policy for late reports**

- You can have **ONE “late ticket”** for a **“free”** delay of up to **3 business days**, but you must tell us you are using the ticket
- Reports are due at midnight on the date shown on the syllabus. After that we will charge:
  - 5 points for up to 1 week late. 10 points for up to 2 weeks late.
  - After that, it's too late.



C1-Ex1(2.16.22)



# Outline

- I. Goals of the course
- II. Teamwork / grades / expectations from you
- III. Syllabus and schedule**
- IV. Your working mode
  - In class and “after hours” access
  - Safety, Responsibility
  - Home and away computing
- V. Take a Lab tour !
- VI. Let’s get started
  - electronic logbooks
  - digital scopes



# Syllabus

	Date	Day	Activity		Lectures: 10am Journal club: 3pm	Note	Due days
			8am-noon	1pm-5pm			
1	6/14	Tuesday	Orientation		About Phy403		
2	6/15	Wednesday	Cycle 1-1	Cycle 1-1	OriginPro, ROOT Intro		
3	6/21	Tuesday	Cycle 1-1	Cycle 1-1	Error analysis		
4	6/22	Wednesday	Cycle 1-1	Cycle 1-1	Written Reports		
5	6/28	Tuesday	Cycle 1-2	Cycle 1-2	Ferroelectricity		
6	6/29	Wednesday	Cycle 1-2	Cycle 1-2	Superconductivity		C1-Ex1(7.01.2022)
7	7/05	Tuesday	Cycle 1-2	Cycle 1-2	Oral Reports/Talks		
8	7/06	Wednesday	Cycle 2-1	Cycle 2-1	Lock-in Amps and FT		
9	7/12	Tuesday	ORALS Cycle 1				
10	7/13	Wednesday	Cycle 2-1	Cycle 2-1	Optical Spectroscopy		C1-Ex2(7.15.2022)
11	7/19	Tuesday	Cycle 2-1	Cycle 2-1	Nuclear Physics		
12	7/20	Wednesday	Cycle 2-2	Cycle 2-2	AFM		
13	7/26	Tuesday	Cycle 2-2	Cycle 2-2	Entanglement		C2-Ex1(7.29.2022)
14	7/27	Wednesday	Cycle 2-2	Cycle 2-2	High Energy Physics		
15	8/02	Tuesday	FINAL ORALS				
16	8/04	Thursday			READING DAY		C2-Ex2(8.06.2022)

Cycles



\* Lecture topics are subject to change

	<b>NP</b> A. Cosmic Muon Stand i. Muon lifetime ii. Capture rate iii. Magnetic moment B. Alpha range C. Gamma Gamma D. Muon telescope E. Mössbauer spectroscopy	<b>CM</b> A. Ferro 1 B. Ferro 2 (imaging) C. 2 <sup>nd</sup> sound of <sup>4</sup> He D. Hysteresis loops E. Tunneling F. Superconductivity #2	<b>Atomic + CM</b> A. Optical pumping B. Superconductivity C. Mutual inductance D. pNMR	<b>Optics</b> A. Quantum Table i. Berry's phase ii. Quantum erasure iii. Entanglement B. Fluorescence spectroscopy C. AFM
	<b>Alexey</b>	<b>Eugene</b>	<b>Vishal</b>	<b>Vishal, TAs from Kwiat Lab</b>
<b>C1-1</b>	1,5	2,4	3,6	
<b>C1-2</b>		2,5	1, 4	3,6
<b>C2-1</b>				
<b>C2-2</b>				





Cycle	#	Experiment
<b>C1-1</b>	2,4	Second sound
	1, 5	Alpha range
	3, 6	Optical Pumping



# Assignment of experiments

2 cycles with 2 experiments

→ you will have different partners

→ joint team reports and elogs but oral

presentations will be done by each

student individually



# Summer 2022 Orals Physics 403

After 2 experiments (1 cycle) we will have an oral presentation session. The topic of the presentation will be chosen from the experiments done in that cycle.

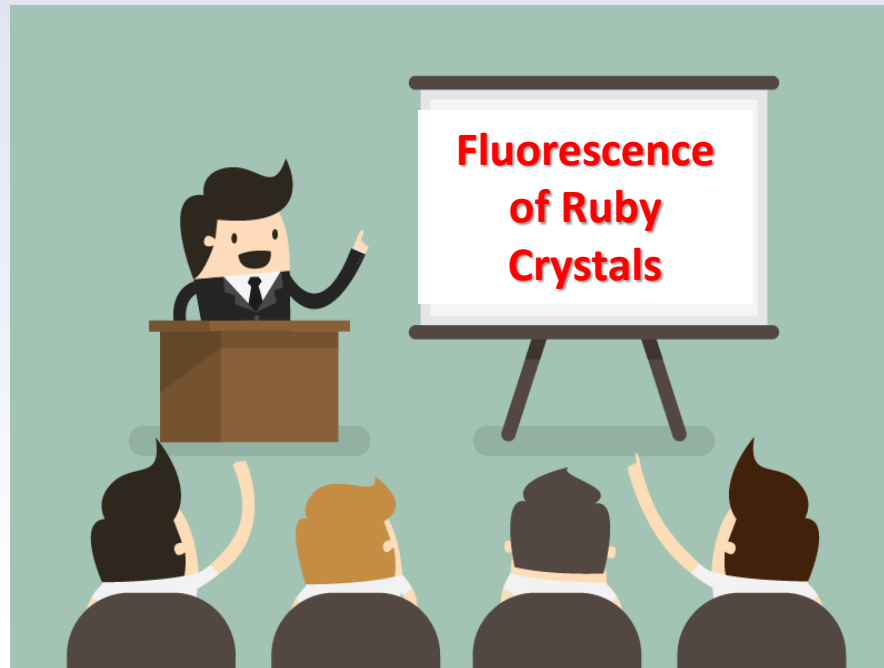

# Outline

- I. Goals of the course
- II. Teamwork / grades / expectations from you
- III. Syllabus and schedule
- IV. Your working mode**
  - In class and “after hours” access
  - Safety, Responsibility
  - Home and away computing
- V. Take a Lab tour !
- VI. Let’s get started
  - electronic logbooks
  - digital scopes





# Lab Access

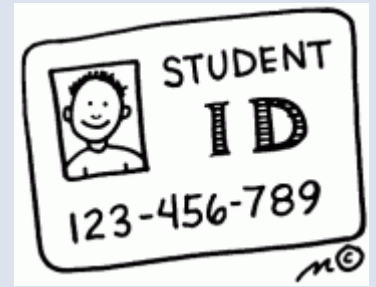

**Use Your ID Card to Access the Lab**

**You can access the Lab not only on “Lab days”**

**Late time rules:**

**You can stay in the Lab until 8pm but need to work with partner**

**After 8pm and on weekend days – *you have to discuss this schedule with your instructor* and in general it is preferable to avoid working after 8 pm and on weekends**



# Safety is your responsibility !

Hazards: *high voltage, radioactive sources, cryogenics, chemical materials, high pressure*

In class work and ~~“after-hours” access~~ work requires responsible conduct with regards to

(I) safety/hazards and with

(II) equipment

Discuss potential hazards at the beginning of each experiment with an instructor or TA

When in doubt stop and ask



# Follow Directly the Recommendations of Safety Working

<https://www.drs.illinois.edu/>

**RESEARCH SAFETY**

Accident Response ▾ DRS Safety Programs ▾ Training ▾ Waste Management ▾ Safety Library ▾

My Campus User Login

**(Material) Safety Data Sheets**  
Find safety data sheets for material you work with in your lab.

**NEWS AND ANNOUNCEMENTS** [VIEW ARCHIVE »](#)

**Laser Registration and Management**  
9/23/2018  
The Division of Research Safety has added a tool to their website to allow laser users to manage their laser registrations and inventory on-line.

**New Tier 1 Select Agent**  
9/23/2018  
As of 9/14/16, the CDC/HHS has added Bacillus cereus Biovar anthracis as a Tier 1 select agent under 42 CFR Part 73.

**Laser Safety Eyewear Warning**  
7/6/2018  
Filters not matching specifications on packaging

**RESPONSIBILITIES**

- I work in a lab
- I supervise a lab
- My work takes me into labs

# Follow Directly the Recommendations of Safety Working

Related Units @ Illinois Questions?

Division of  
**RESEARCH SAFETY**

Accident Response ▾ DRS Safety Programs ▾ Training ▾ Waste Management ▾ Safety Library ▾

## Chemical Waste Collection and Storage

Before generating chemical waste, the researcher should determine how it will be collected and stored and obtain the necessary equipment (containers, labels) in advance. The choice of procedures depends on the type of waste and its final disposition. This section explains how to determine the final disposition of waste, select the appropriate waste container, and store waste in the lab or work area. It also suggests waste minimization strategies.

### Determining How to Dispose of a Chemical Waste

The final disposition of a chemical waste is determined by the answers to a series of questions:

- Step 1.** Is the waste [Contaminated Debris](#) (glassware, paper towels, clean-up materials), or is it a chemical or chemical mixture?  
**If it is contaminated debris:** Go to Step 5.  
**If it is a chemical or chemical mixture:** Go to Step 2.
- Step 2.** Is the chemical a DEA (Drug Enforcement Agency) controlled substance? (Refer to the [DEA list controlled substances](#).)  
**Yes:** Refer to the [DEA Controlled Substances Guide](#) for disposal procedures.  
**No:** Go to Step 3.
- Step 3.** Is the chemical a solid (not liquid or gas)?  
**Yes:** Collect and store the waste as described in the waste container and storage guidelines listed below and dispose of it through the Division of Research Safety (DRS) chemical waste disposal program. See the section [Procedures for Requesting Chemical Waste Disposal](#) for the disposal procedures. (No solid chemical waste, hazardous or non-hazardous, should be placed in the regular trash.)  
**No:** Go to Step 4.
- Step 4.** Is the chemical a liquid non-hazardous waste as listed in the section [Liquid Non-Hazardous Chemical Waste Disposal?](#)  
**Yes:** The chemical may be poured down the sanitary sewer (sink drain) with copious amounts of water.  
**No:** Collect and store the waste as described in the waste container and storage guidelines listed below, and dispose of it through the DRS chemical waste disposal program. See the section [Procedures for Requesting Chemical Waste Disposal](#) for the disposal procedures.
- Step 5.** Is the contaminated debris laboratory glassware (broken and unbroken)?  
**Yes:** See the [Laboratory Glassware Waste Disposal](#) section.  
**No:** Go to Step 6.
- Step 6.** Is the debris contaminated with a substance listed in the section [Liquid Non-Hazardous Chemical Waste Disposal?](#)  
**Yes:** The contaminated debris can be disposed of in the regular trash.  
**No:** Collect and store the contaminated debris as described in the waste container and storage guidelines listed below: dispose



**Waste container for ethanol, acetone, methanol, isopropanol.**



**Waste container for mineral spirits.**



**Waste containers for chemicals used in NMR experiment**



# Follow Directly the Recommendations of Safety Working

Related Units @ Illinois Questions? Search Go

Division of **RESEARCH SAFETY**

Accident Response ▾ DRS Safety Programs ▾ Training ▾ Waste Management ▾ Safety Library ▾

Profile ▾ Eugene V Colla ▶ Log off

## Laboratory Sharps

### Definition

Materials that qualify as “sharps” are defined at the state level and shall be disposed of as Potentially Infectious Medical Waste (PIMW). In Illinois, the Illinois Environmental Protection Agency (IEPA) has designated the following material (used or unused) as sharps:

- Any medical needles,
- Syringe barrels (with or without needle),
- Pasteur pipettes (glass),
- Scalpel and razor blades,
- Blood vials,
- Microscope slides and coverslips,
- Glassware contaminated with infectious agents.

### **NEVER** dispose of these items in SDCs:

- Plastic items (except for syringes),
- Beverage containers (no pop cans!),
- Non-biologically contaminated laboratory glassware,
- Solvent/chemical bottles,
- Light bulbs,
- Any paper materials,
- Pipette tips,
- Plastic pipettes,
- Aerosol cans or cans of any type,
- Scintillation vials,
- Any item with liquid (except for blood in vacutainer tubes).



**Waste  
container for  
sharps**



# Outline



**V. Take a Lab tour! For those online it will be a virtual tour.**

VI. Let's get started  
electronic logbooks  
digital scopes



# Outline

- I. Goals of the course
- II. Teamwork / grades / expectations from you
- III. Syllabus and schedule
- IV. Your working mode  
In class and “after hours” access  
Safety, Responsibility  
Home and away computing
- V. Take a Lab tour !
- VI. Let's get started**  
electronic logbooks  
digital scopes



# How to record the data

- **Work together**
- **Write down the equipment used**
- **Make a diagram of the setup**
- **Note the settings of dials, switches, gauges**
- **Take a digital photo if appropriate (we have prepared and will prepare more pictures of the setups equipment etc.)**
- **Use a software drawing program to make a detailed sketch (PowerPoint works for this very well)**





# How to record the data

- Use the eLog (see next).
- Write down what you did in real sentences.
- Provide enough detail that you can reconstruct later what you did!
- How will you look at the data later?
- Do you have enough information?
- Did the equipment perform as expected?



# How to record the data

- Many experiments require you to “change and measure” something by hand
  - Make a **table** in a **paper logbook** or **put the data directly into electronic worksheet (*preferable*)**.
  - Make a “**quick sketch**” of your by plotting the data using OriginPro or other software

Looking on the graph you can answer the questions:

- Do you have enough points?
- Do you have any obvious anomalies?
- You can repeat points but do not throw them out.  
Use other measurements to check reliability



# How to record the data

- Many experiments have built-in, computer-based data

## acquisition (DAQ)

- You will not have time to fully understand the DAQ, but

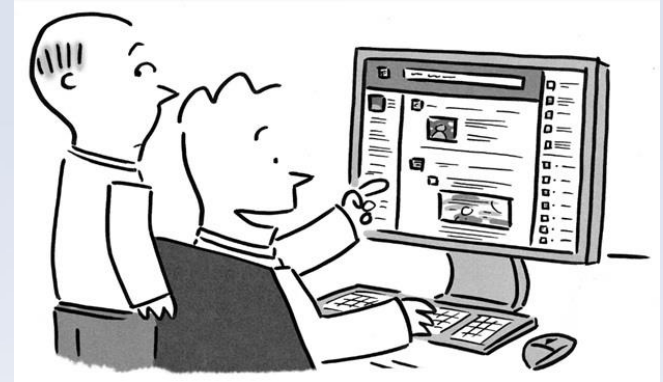

- Be sure you know functionally what it is doing – ask
- A good idea is to make test measurements of something you know
- As before, anomalies? enough points? uncertainties?



# Where to exchange, store and retrieve course information.

## P403 Lab server

<\\engr-file-03.engr.illinois.edu\PHYINST\APL Courses\PHYCS403>

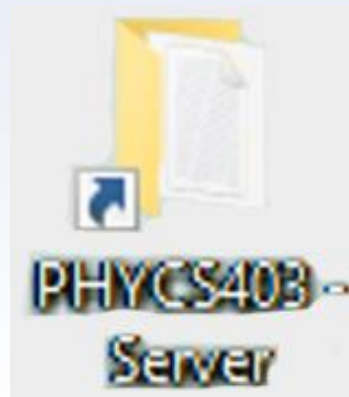

# Connecting to the PHYS403 server

Connect to VPN following the instructions on the UIUC VPN website:

<https://techservices.illinois.edu/services/virtual-private-networking-vpn/download-and-set-up-the-vpn-client>

## To connect to the PHYS403 Server:

- **Connect to the VPN first, then enter the following as the share to connect to:**
  - **Mac users:** Open Finder: Go: Connect to Server, type in address:  
smb://engr-file-03.engr.illinois.edu/PHYINST/APL Courses/PHYCS403
  - **Windows users:** Open Windows Explorer, type in address:  
<\\engr-file-03.engr.illinois.edu\PHYINST\APL Courses\PHYCS403>
- **When prompted for username and password, enter:**  
“Uofl\[your netID]” and “[your netID password]”





# Where to exchange, store and retrieve course information.

*(i) Your data, projects, tables etc*

\\engr-file-03\PHYINST\APL Courses\PHYCS403

There is a lot **useful** and not very useful stuff in many folders you can find there

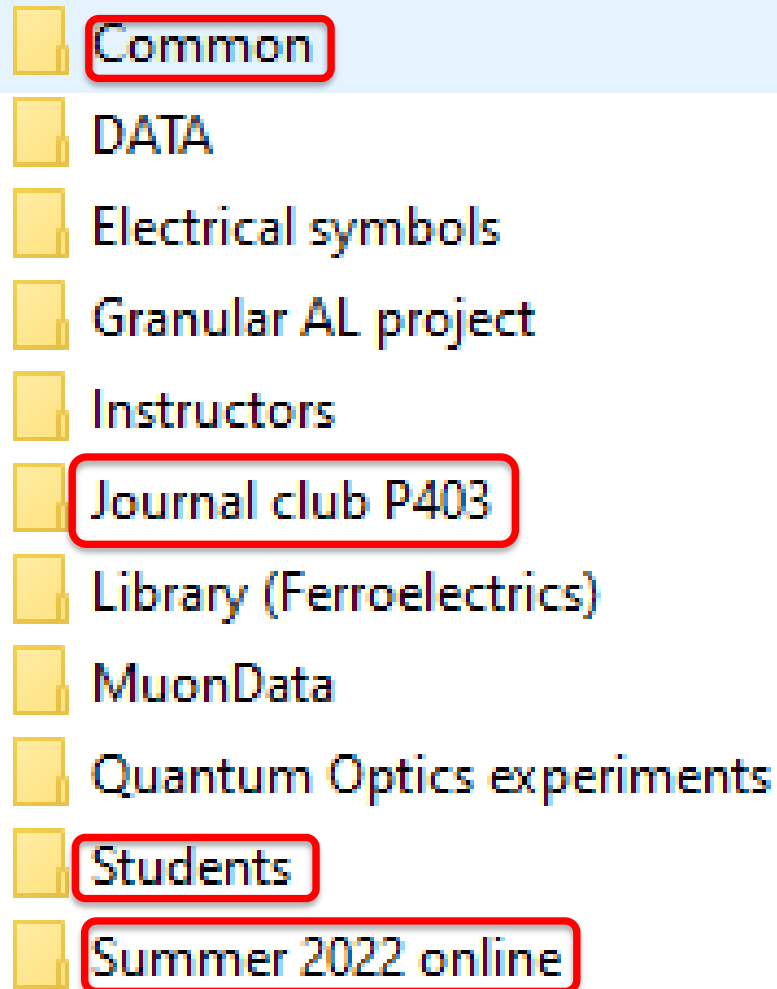

**“Useful”  
folders are  
shown in red  
frames**



# Where to exchange, store and retrieve course information.

*(i) Your data, projects, tables etc*

\\engr-file-03\PHYINST\APL Courses\PHYCS403

Each student has a folder

- Library
- MuonData
- Students
- Summer 2020 online
- Summer research

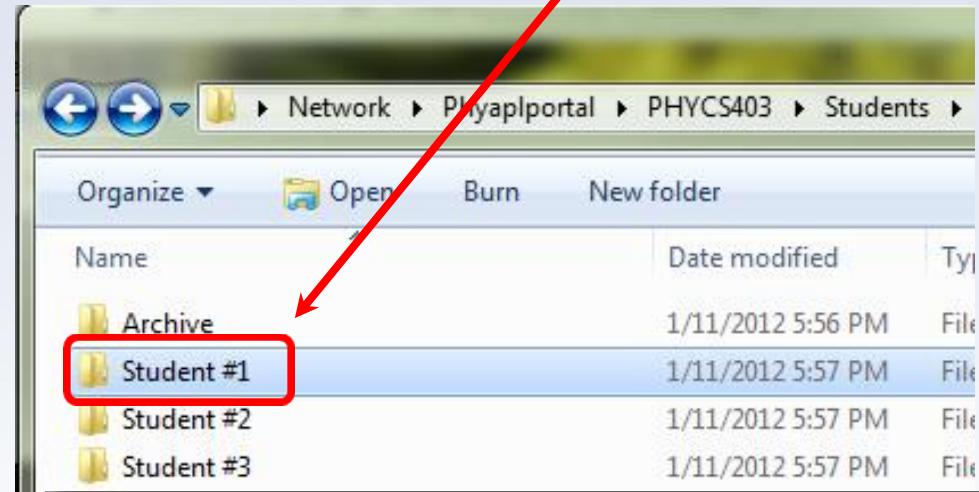

Store all experiment related materials in corresponding folder

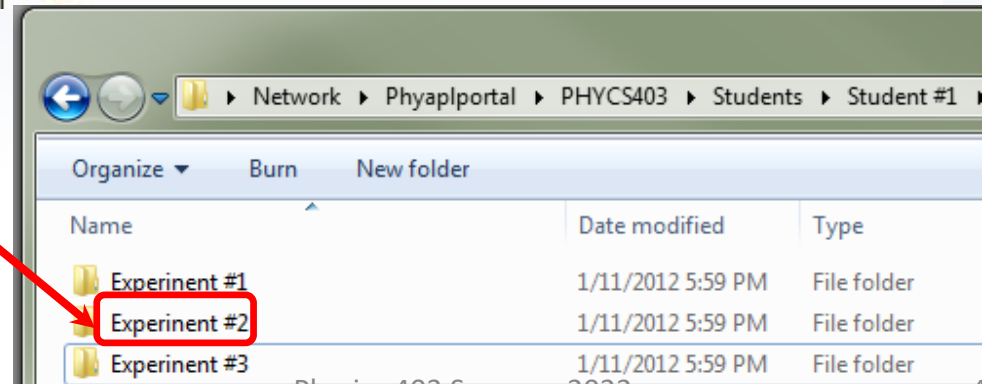

# Where to exchange, store and retrieve course information. (i)

## *Your data, projects, tables etc*

An example of the “smart” structure of folders containing the raw data and data analysis projects

The image displays three screenshots of Windows Explorer windows illustrating a hierarchical folder structure for course data and analysis projects. Blue arrows indicate the flow of navigation between the windows.

**Top-Right Window:** Shows the path `Network > Phyapportal > PHYCS403 > Students > Student #1`. The file list includes:

Name	Date modified	Type
Experinent #1	1/11/2012 5:59 PM	File folder
Experinent #2	1/11/2012 5:59 PM	File folder
Experinent #3	1/11/2012 5:59 PM	File folder

**Bottom-Right Window:** Shows the path `<< Students >> Archive >> Fall 2010 Backup >>`. The file list includes:

Name	Date modified
Lab3Ferroelectrics	10/14/2010 8:...
Data_Analysis	10/7/2010 5:4...
e' vs T #1.OTP	4/19/2006 11:...
Temperature Profile	10/5/2010 2:4...
Temperature_Profile	10/5/2010 2:4...
temperatureProfile	10/5/2010 2:4...

**Left Window:** Shows the path `<< Archive >> Fall 2010 Backup >>`. The file list includes:

- DKDP\_run1
- DKDP\_run2
- DKDP\_run3 (sample 2 pins 2&5)
- DKDP\_run4 (sample 1 a-cut)
- DKDP\_run5(sample 4 c-cut)
- DKDP\_run6(sample 4 c-cut)
- DKDP\_run7(sample 4 c-cut)
- DKDP\_run8(sample 4 c-cut)
- DKDP DC bias runs (Eugene)
- DKDP run 8 250V and diff rates (eugene)

# Where to retrieve course information.

**Manuals, papers, setup diagrams and other useful materials**

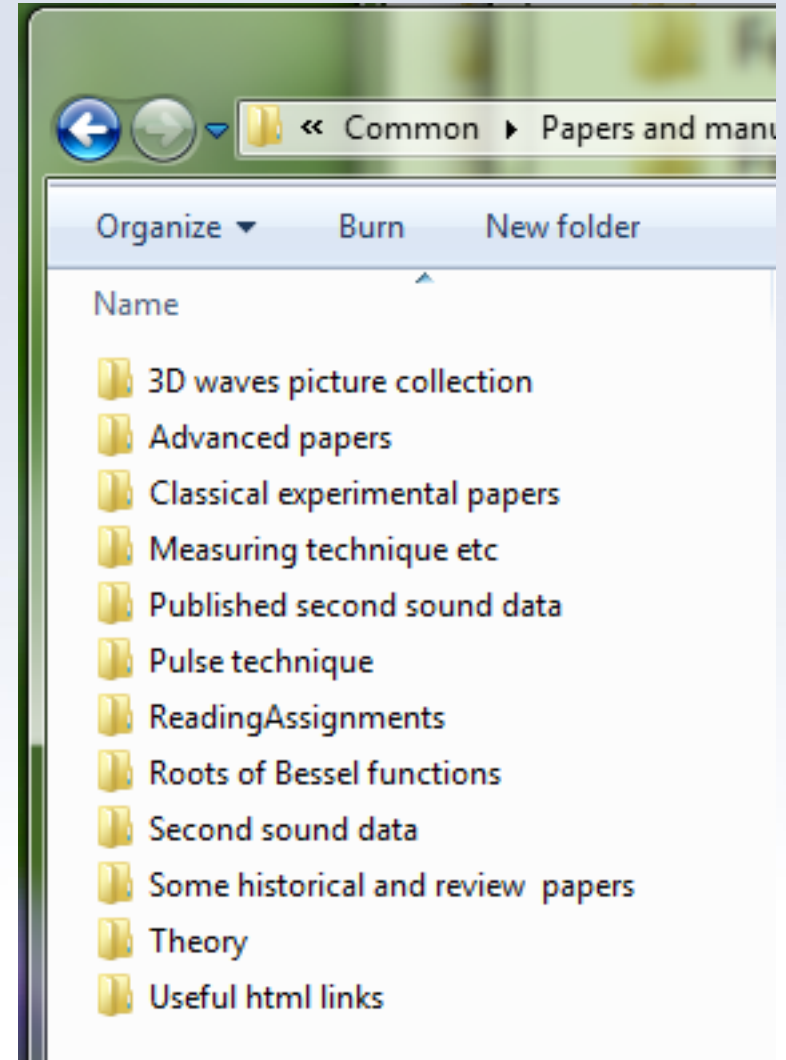
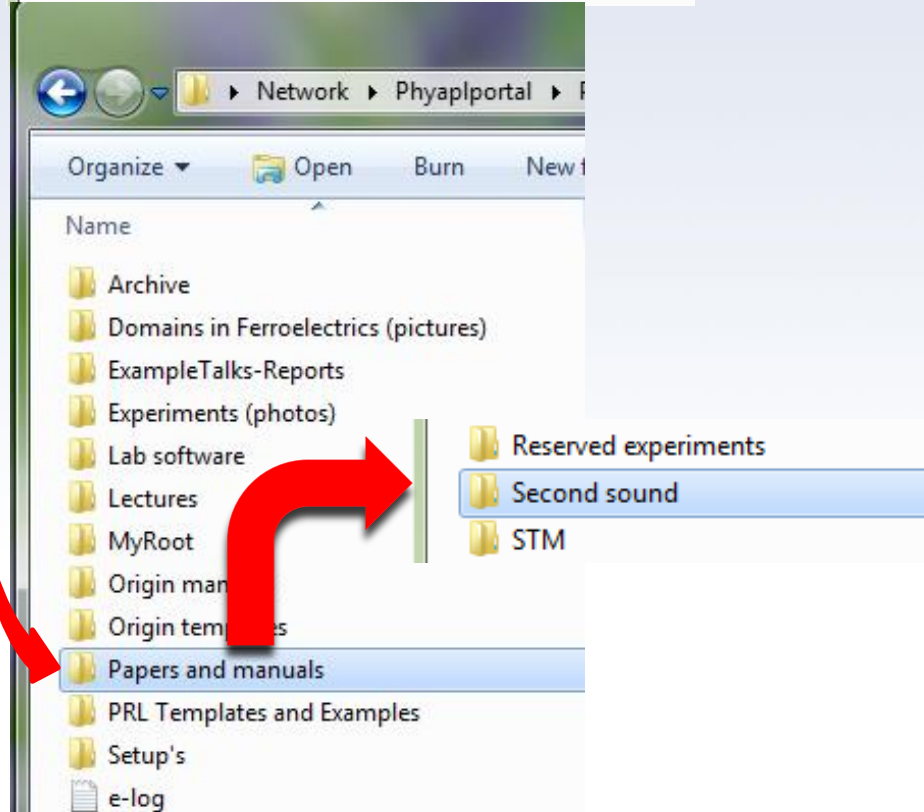
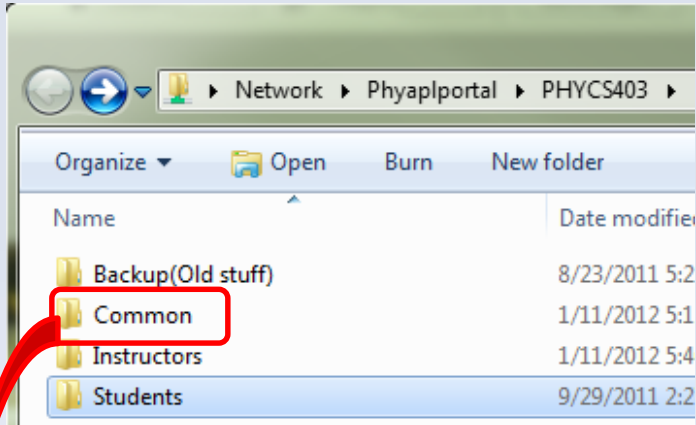

# Where to retrieve course information.

Manuals, papers, *setup diagrams* and other useful materials

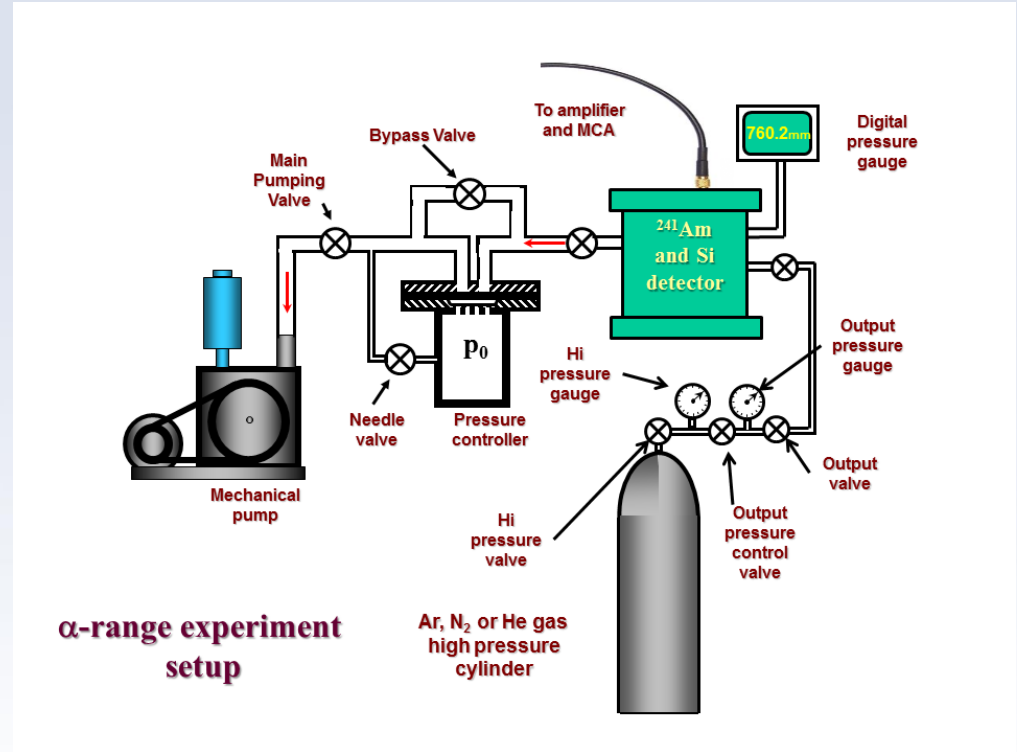
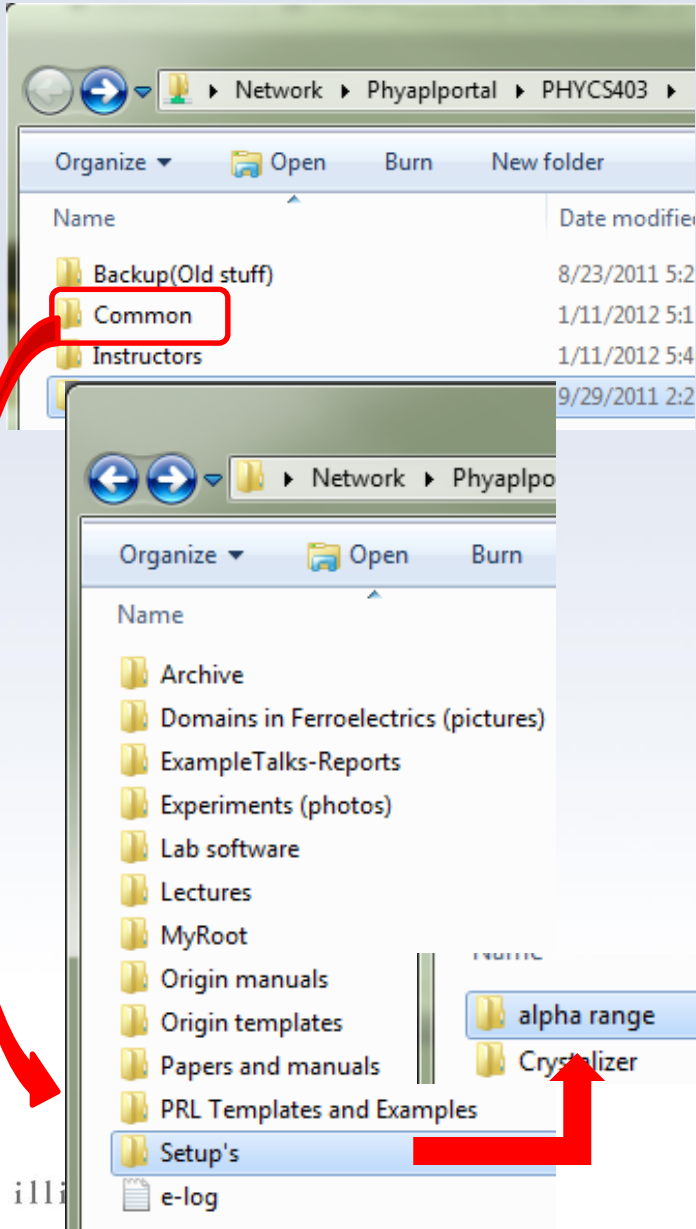

$\alpha$ -range experiment setup

$\alpha$ -range experiment setup diagram



# Where to retrieve course information.

Manuals, papers, *setup diagrams* and other useful materials in **Summer 2022 online** folder

**Summer 2022 online**

Name

- Alpha Range
- Ferro1
- Ferro2
- Ferro3
- Fluorescence
- gamma-gamma
- Inroduction (videos)
- Moessbauer
- Muon Lifetime
- Optical Pumping
- PNMR
- Quantum Entanglement
- Quantum Erasure
- Second Sound
- Superconductivity
- Superconductivity 2
- Tunneling

- Reading materials
- references
- Setup
- Software

- Giaever.pdf
- Giaever\_1960\_Electron Tunneling
- Giaever lecture.txt
- MIT10\_626S14\_Lec20.pdf
- Tunneling Experiment.docx
- tunneling.pdf

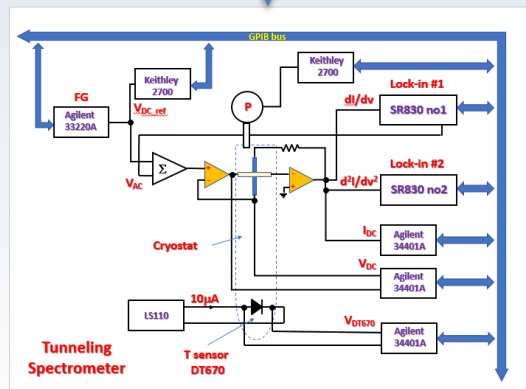

1. Schiff\_L.I.\_Quantum\_mechanics\_(1949)...
2. Giaever\_Study of Superconductors by El...
3. Tinkham\_M.\_Introduction\_to\_superco...
4. J. Bardeen, L. N. Cooper, and J.R. Schri...
5. Giaever. Energy Gap in Superconducto...
6. GROWTH OF THIN ALUMINA FILM.pdf
7. London Superfluid.pdf
8. Gap Value Determination on the Tunne...

**These folders contain almost everything you need to work on experiment**



# Where to retrieve course information.

Setup diagrams – do not use cellphones to take the image of the setup from manual – for most setups we have PowerPoint projects with setups.

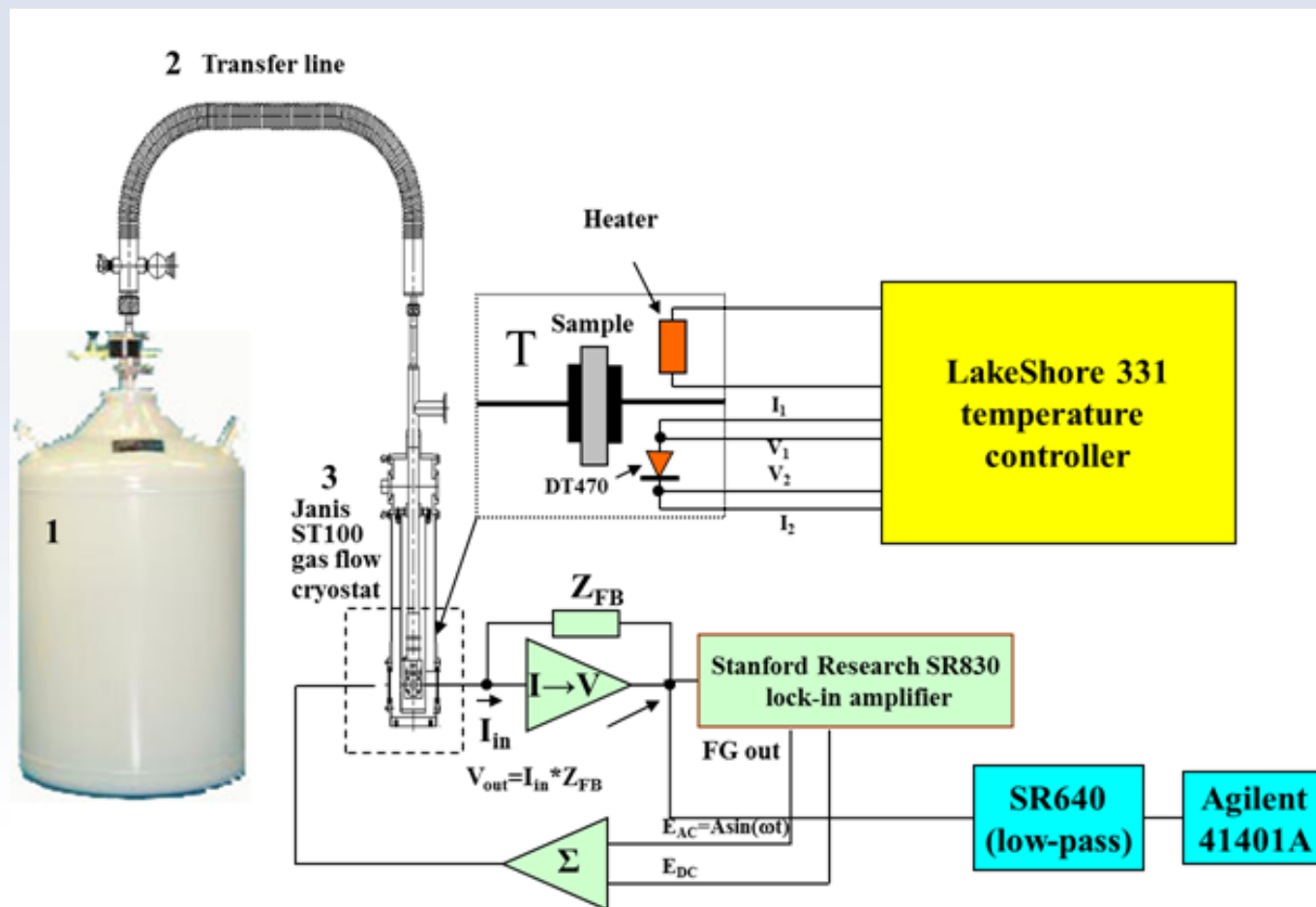

# “Journal club”

Lectures – Tuesdays 3pm

Journal Club – Thursdays 3pm

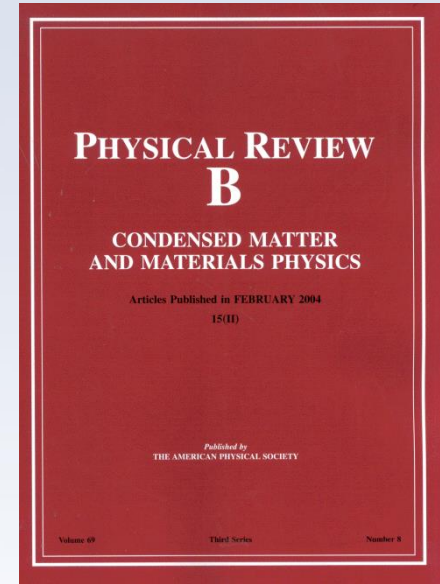
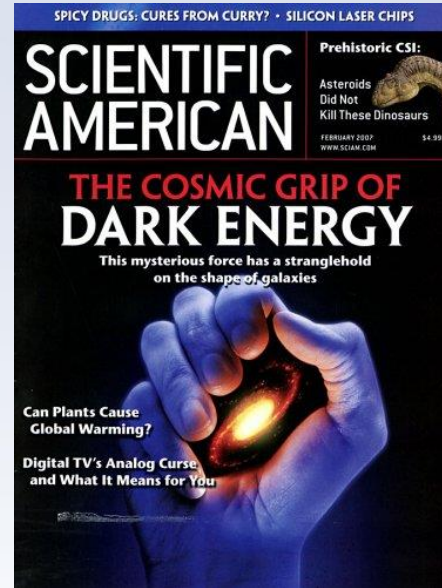
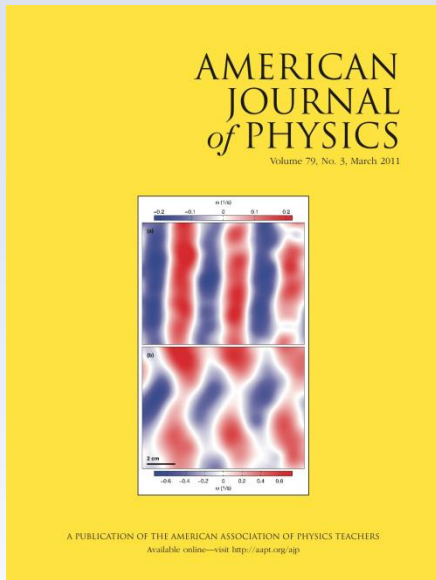

<http://ajp.aapt.org/#mainWithRight>

<http://www.nature.com/nature/index.htm>

<http://www.scientificamerican.com/>

<http://www.sciencemag.org/journals>



<http://publish.aps.org> or <http://prola.aps.org/>

# “Journal club”

Walking with Coffee: Why Does it Spill?

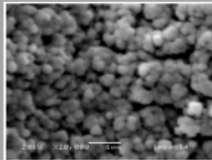

## Growth of Diamond Films from Tequila

J. Morales<sup>1,2</sup>, L. M. Apátiga<sup>2</sup>, V. M. Castaño<sup>2</sup>

1. Facultad de Ciencias Físico Matemáticas, Universidad Autónoma de Nuevo León
2. Centro de física Aplicada y Tecnología Avanzada, Universidad Nacional Autónoma de México

## Fabrication and Characterization of Ultrathin Three-Dimensional Thermal Cloak

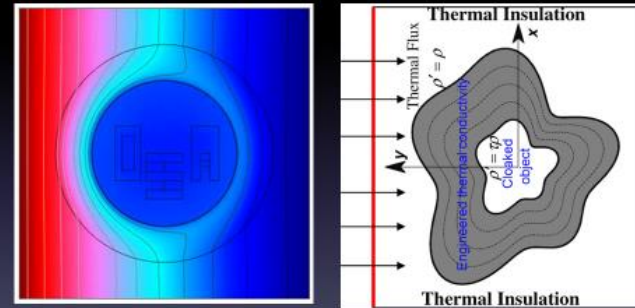

(Credit: Guennea)

Student #1

University of Illinois at Urbana-Champaign

## The Physics of Beer Tapping

PRESENTATION BY JOSEPH MIRABELLI

JAVIER RODRÍGUEZ-RODRÍGUEZ, 1,\* ALMUDENA CASADO-CHACÓN, AND DANIEL FUSTER

1 FLUID MECHANICS GROUP, CARLOS III UNIVERSITY OF MADRID

2 CNRS, UNIVERSITÉ PIERRE ET MARIE CURIE



# “Journal club”

## ***Journal Access***

If you cannot access journal papers using VPN, go to UIUC’s library proxy test site and enter the address of the paper you want to read:

<http://www.library.illinois.edu/proxy/test/>

## ***Recommended journal websites***

- **American Physical Society Journals:** <https://journals.aps.org/about>
- **Nature:** <http://www.nature.com/nature/index.html>
- **Science:** <http://www.sciencemag.org/journals>
- **American Journal of Physics:** <http://scitation.aip.org/content/aapt/journal/ajp>





# Entering the e-Log ...

Home  
Course Schedule  
Gradebook

Course Description  
Course Grading  
Contact Information  
Experiment Information  
Lectures  
Online Materials  
Final Oral Session Abstracts  
References

**E-LOG**

Section Information

## PHYS 403 Spring 2022

Home page

**Link to e-Log**



# Entering the e-Log ...

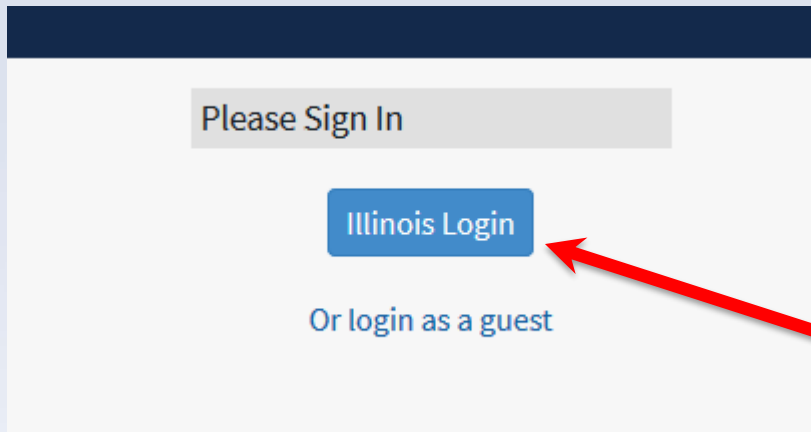

**Use your University  
Username and  
Password**



# Entering the e-Log ...

**ELOGS**

[View Books](#) [View Logs](#)

**Your eLog Books**

- Physics 403 Spring 2022 rwiltfon 1/5/2022 2:02:44 PM
- Physics 403 Fall 2021 kolla 8/23/2021 10:17:42 AM
- Physics 403 Summer 2021 kolla 6/2/2021 5:10:40 PM
- Physics 403 Summer 2022 kolla 5/31/2022 10:41:49 AM
- Physics 403 Spring 2021 rwiltfon 1/12/2021 2:55:39 PM

*Summer 2022 elog folder*



# Entering the e-Log ...



The Grainger College of Engineering  
Physics

My.Physics ▾ HR ▾ Finance ▾ Facilities ▾ Research ▾ Academic ▾ Out

## ELOG: VIEWING LOGS WITHIN PHYSICS 403 SUMMER 2022

View Books

View Logs

Create New Log

*Create new elog record*

Search this book

Reset Search

Logs

<input type="checkbox"/>	ID	Date	Authors	Experiment	Post Type	Subject	Attachments
<input type="checkbox"/>	1234	6/9/2022 2:09:58 PM	Eugene Colla		Other	Welcome	

View Selected Logs



# Entering the e-Log ...

## ELOG: EDITING LOG FROM PHYSICS 403 SUMMER 2022: NEW SUBJECT

View Books

View Logs

[View all Physics 403 Summer 2022 logs]

The name of your partner

Editing log: New subject

Entry time

6/9/2022 2:13:39 PM

First author

Eugene Colla

Second author

Start typing name, select netID

Third author

Start typing name, select netID

Experiment

- please select -

Post type

- please select -

Load Template

Use templates for preparing the post

The title of the experiment

Post type





# Entering the e-Log ...

Choose a template

The template you chose will be inserted after any text you may already have in your log.

Available templates

First day record

The main goal of the experiment:

Technique:

Subject of study:

Insert Template

Pop-up list of available templates

Add template to your log



# e-logs: Making a post...

## How to use it

- **Pause and summarize your work at natural stopping points in the action. This is useful for particular findings and measurement sequences.**
- **Along the way, save data, plots, scope shots to your folder on the server.**
- **Near the end of the class, add a summary/conclusion, indicate future directions, and make sure the e-log provides a rather complete overview of the highlights of your work. Upload your plots, scope shots, etc. and describe the data.**

# e-logs: Making a post ...

Author:	Your name and your partner's name
Experiment:	General
Post Type:	How-To
Subject:	Day [#]: brief description of work

Goal: Be specific. Not, "Learn about experiment," but, for example, "In helium below temperatures of 2.17K, a second sound due to thermal effects becomes measurable. We will measure second sound using a resonant cavity..."

Settings / Equipment Notes: Note important environmental and experimental parameters such as atmospheric pressure, settings on equipment, etc.

[Time Range 1]: Give time range, not just "before tea."

- Note important steps and results
- Include plots, photos, or scope shots in attachments below
- Use bullet points to make it easy to read

[Time Range 2]: ...

Conclusions & Future Plans: What did you find and what is the next step? Be specific. Not, "We measured decay times," but, for example, "Ruby #2 sample with higher concentration chromium was observed to decay with a form..."

# Some General Physics 403 Rules.



**No Food or Drinks in Lab !  
Except ESB5105**

